



INSTALLATION INSTRUCTIONS FOR PART 99-7862

APPLICATIONS

Honda Accord 2003-2007 99-7862

KIT FEATURES

- DIN radio provision with pocket
- ISO DIN radio provision with pocket



KIT COMPONENTS

- A) Radio Housing
- B) ISO Brackets
- C) ISO Trim Plate
- D) Radio "T" Harness

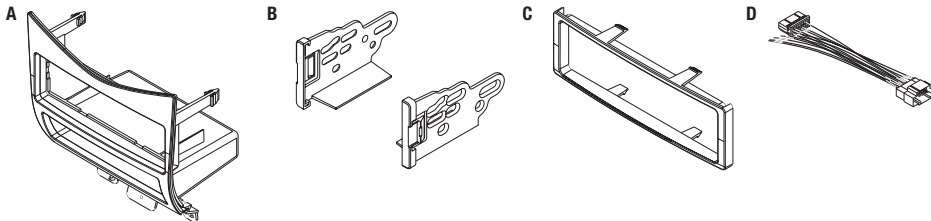

WIRING & ANTENNA CONNECTIONS (sold separately)

- Wiring Harness: • Harness Included
- Antenna Adapter: • Not required

Table of Contents

Dash Disassembly

- Honda Accord 2003-2007 2

Kit Assembly

- DIN radio provision with pocket..... 3
- ISO DIN radio provision with pocket..... 3

TOOLS REQUIRED

- Panel removal tool
- Phillips screwdriver
- Socket Wrench

CAUTION: Metra recommends disconnecting the negative battery terminal before beginning any installation. All accessories, switches, and especially air bag indicator lights must be plugged in before reconnecting the battery or cycling the ignition.

NOTE: Refer to the instructions included with the aftermarket radio.

Dash Disassembly

1. Unsnap and remove shift lever trim ring. (Figure A)
2. Unsnap coin tray/ashtray from assembly and remove. The rubber cover may come out first but entire assembly must be removed to access screws below. (Figure B)
3. Remove (2) Phillips screws from under coin tray/ashtray and remove entire assembly. (Figure C)
4. Remove (2) Phillips screws from bottom of pocket assembly and unsnap and remove. (Figure D)

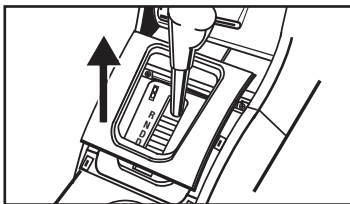

(Figure A)

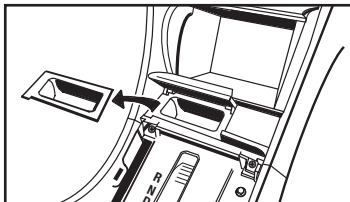

(Figure B)

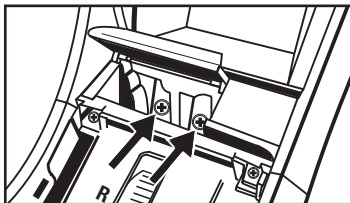

(Figure C)

5. Remove (2) Phillips screws facing up under radio/climate control assembly. (Figure E)
6. Unsnap and remove upper panel (including a/c vents) and remove (3) Phillips screws behind the panel. (Figure F)

Tip: You can use a hook tool to grasp the panel inside of the vent and pull toward the rear of the vehicle. Be careful not to scratch the panel.

7. Unclip and remove radio/climate control assembly.

Continue to kit assembly

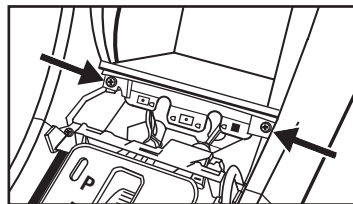

(Figure D)



(Figure E)

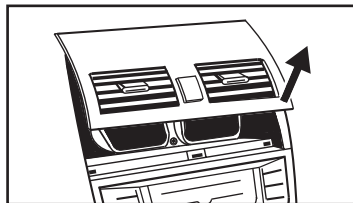

(Figure F)

Kit Assembly

DIN radio provision

1. Snap the DIN cage into the radio housing and secure by bending the metal locking tabs down. (Figure A)
2. Slide the aftermarket radio into the cage and secure. (Figure B)
3. Make wiring connections using the Metra/EIA Wiring Code chart shown on back page, and the instructions included with the radio.
4. Disconnect the main harness from the factory radio, and connect the included Radio "T" Harness between this harness, and the OE radio.
5. Reassemble dash in reverse order of disassembly.

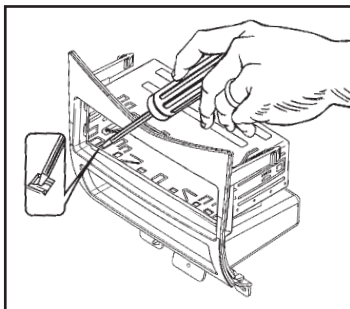

(Figure A)

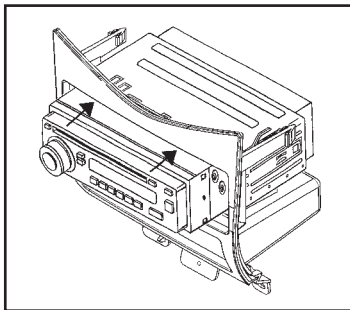

(Figure B)

ISO DIN radio provision

1. Mount the ISO brackets to the radio with the screws supplied with the radio. (Figure A)
2. Slide the radio into the radio opening until the side clips engage. Snap the trim plate into the radio housing. (Figure B)
3. Make wiring connections using the Metra/EIA Wiring Code chart shown on back page, and the instructions included with the radio.
4. Disconnect the main harness from the factory radio, and connect the included Radio "T" Harness between this harness, and the OE radio.
5. Reassemble dash in reverse order of disassembly.

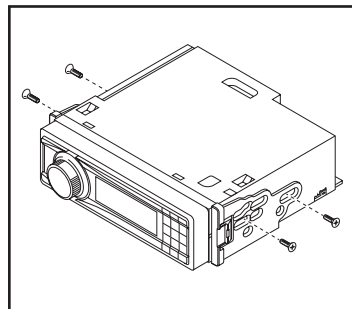

(Figure A)

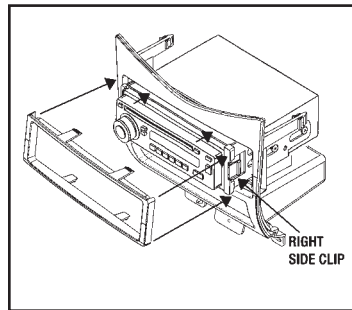

(Figure B)



INSTALLATION INSTRUCTIONS FOR PART 99-7862



Wiring the 99-7862

Metra/EIA Wiring Code

12V Ignition/Acc..... Red	Power Antenna Blue	Illumination..... Orange
12V Batt/Memory..... Yellow	Amp Turn-OnBlue/White	Dimmer Orange/White
GroundBlack	Amp GroundBlack/White	
Right Front (+) Gray	Left Front (-) White/Black	Left Rear (+) Green
Right Front (-) ...Gray/ Black	Right Rear (+) Violet	Left Rear (-) Green/Black
Left Front (+)White	Right Rear (-) ... Violet/Black	



KNOWLEDGE IS POWER

Enhance your installation and fabrication skills by enrolling in the most recognized and respected mobile electronics school in our industry. Log onto www.installerinstitute.com or call 800-354-6782 for more information and take steps toward a better tomorrow.



Metra recommends MECP certified technicians